



Residential Service-Line Installation Guide

Customer Service Support (800) 832-6164; M-F, 9am to 5pm

This is a guide for the installation of a customer-owned natural gas service line. State and Federal Code require that a qualified individual perform work on a natural gas pipeline. All mechanical joints made in plastic gas mains and service lines must be performed using qualified joining procedures. ***If you have a question on the installation of a service line or converting to natural gas, call our Customer Service Support and we will be glad to assist.***

To assist with the installation the following diagrams are included:

- Service line location, orientation, and bury dept.
- Pre-fabricated residential meter drawing and mounting dimensions.

Approved Service Line Material List:

The following material is available at the Mentor & Orwell Service Center locations:

- Standard service line: 1" CTS .099 Wall, Yellow, ASTM D-2513 Plastic Pipe.
- Coated copper trace wire marked "Gas Pipeline" 12 THHN, Solid wire, Yellow.
- Orwell Natural Gas prefabricated meter-bar.
- 1" Pre-bent service line riser. Stock Number #75270.
- 6" Offset wall-bracket. Stock Number #74500.

INSTALLATION REQUIREMENTS:

1. Make application for natural gas service by sending in a completed application. Make certain natural gas service is available in your area. Call Ohio's One-Call-Center, before **your contractor starts excavation**. **"Call before you dig in Ohio (800) 362-2764."** It is a free service. Allow 48 hours for utilities, possibly located in the area, to mark existing underground infrastructure in the area.
2. **Please call Orwell Natural Gas to schedule an appointment to determine meter placement.** The meter must be located on the front our side of the building. The meter is the tie-in point to the building's interior natural gas piping. The minimum distance from a window, vent, or chimney clean-out is four (4) feet and six (6) feet from an electric meter. Place a stake or visible marking at the foundation at the preferred meter location. **We will do our best to place your meter in your desired location.**
3. You may have the option to schedule delivery of the service material to the jobsite. Call our Customer Support for details. You will need to allow us 5 working days to deliver the service line material. The technician will inspect and approve the proposed meter location. If the location is not feasible the technician will mark an alternate location.

4. **(Operator Qualified)** Proceed with the underground installation of the service line and mounting the riser and connected meter setting to the building. A qualified contractor can connect the mechanical joint between the riser and the plastic pipe. You will need to leave your O.Q. number at the meter setting or call us to verify qualification. Qualified contractors can back-fill the entire service line up to the designated bury-depth. Call for final inspection.
5. After the service line inspection, allow two (2) weeks for the service line to be connected into the main pipeline along the street. The Gas Company will tap the service line into the main and pressure test the integrity of the service line. The Gas Company is responsible for tapping the service line into the main and backfilling the trench required to make the connection at the street. The service line will not be connected until the entire underground portion of the service line is back-filled properly to standard
6. For the interior piping use only approved metal piping suitable for natural gas. You will need to check with your contractor or local official for piping and building code requirements in your area. Most ordinances require that each appliance have an accessible manual shut-off installed. Contact your heating contractor to have the interior gas piping installed and inspected. If you are converting from propane to gas service, your interior piping maybe adaptable.
7. Please notify the Gas Company at least five (5) working days in advance to have your natural gas meter installed. Ensure that you or your contractor schedules the meter installation with the Gas Company prior to removing your existing appliance(s) and coordinate a pressure test of the interior piping. The interior piping should have a capped end or a shut-off for the pressure test to hold. If the interior piping fails a pressure test by the Gas Company, a \$35 call-back charge will be assessed.

THINGS TO REMEMBER:

- Call us with **ANY** questions. It will benefit you to call first, rather than make a mistake: **(800) 832-6164**.
- The installer is responsible for a proper installation and any deficiencies are the responsibility of the installer.
- Prior to **ANY** installation or conversion you must make application of service to determine if service is available in your area.
- Ensure the contractor is qualified to Orwell Natural Gas standards or has discussed proper installation procedure with us.
- Allow at least ten (10) days for the service line connection to the main. For state highways allow at least (30) days.
- Call in advance to schedule and verify your meter installation.

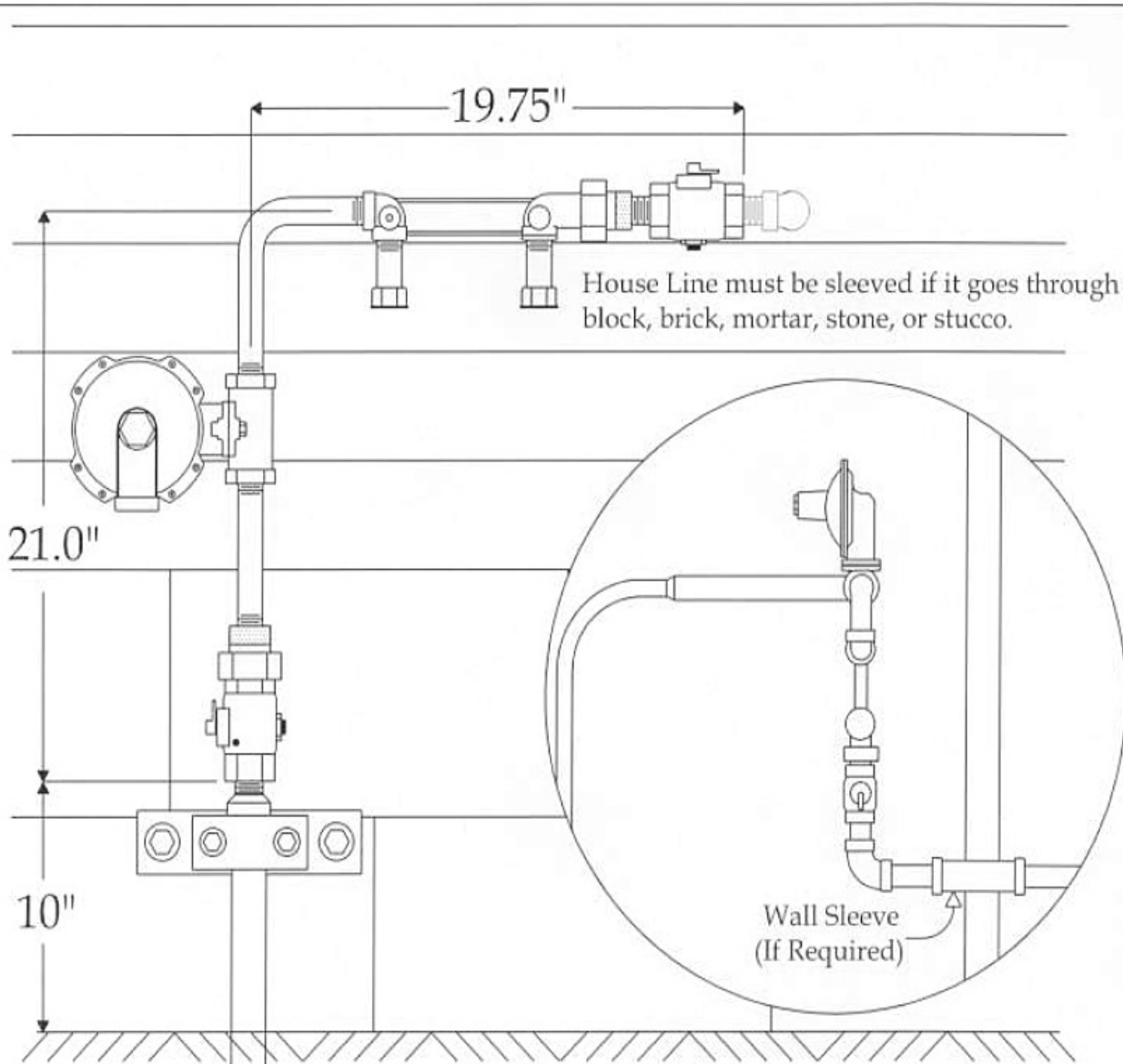

Note: Meter Bar to be installed as shown with outlet valve facing to the right.

**Northeast Ohio
Natural Gas
Orwell Natural Gas
Residential/Small
Commercial Setting
Drawing**

PSM - NEO

Rev. 03-15-2006

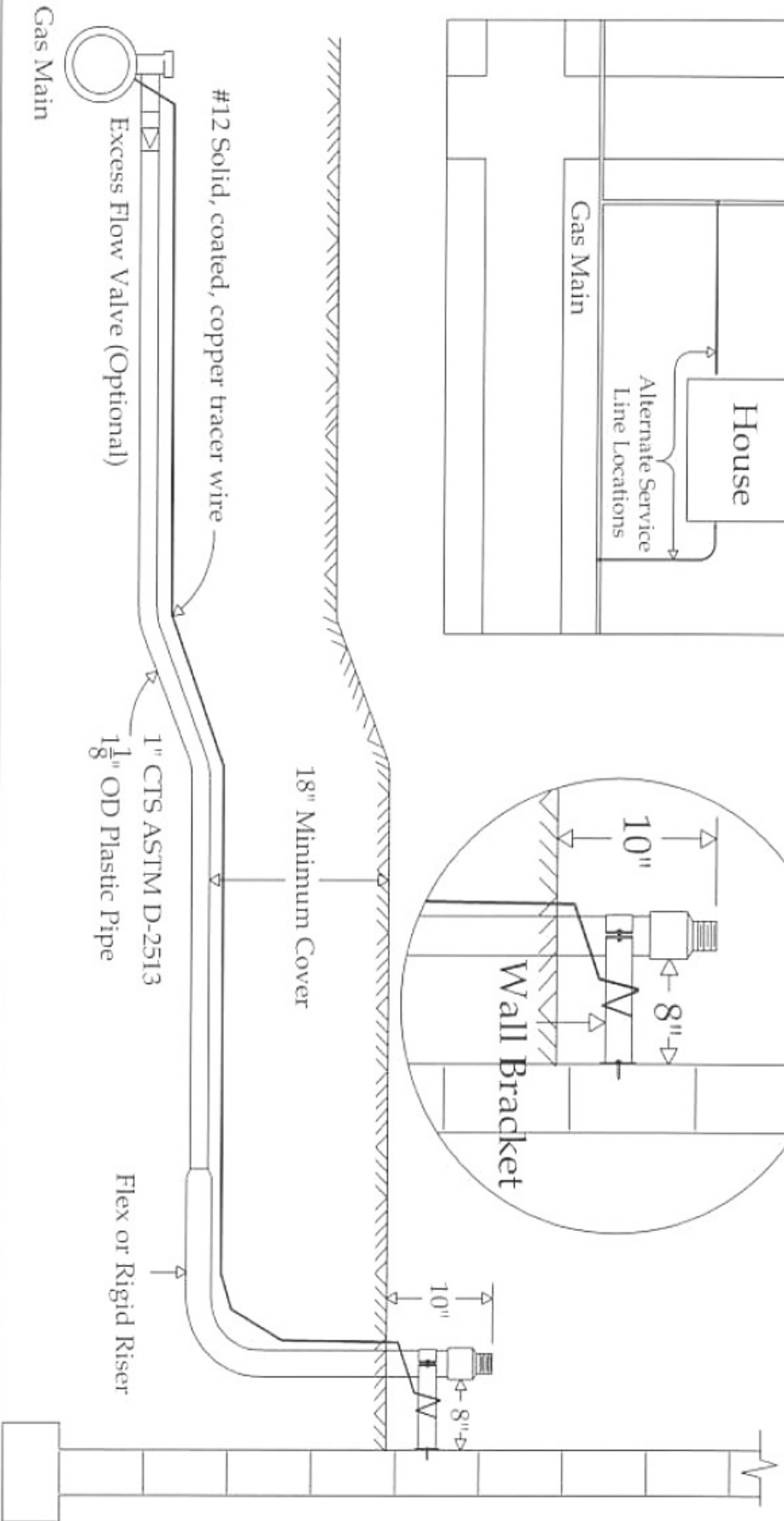
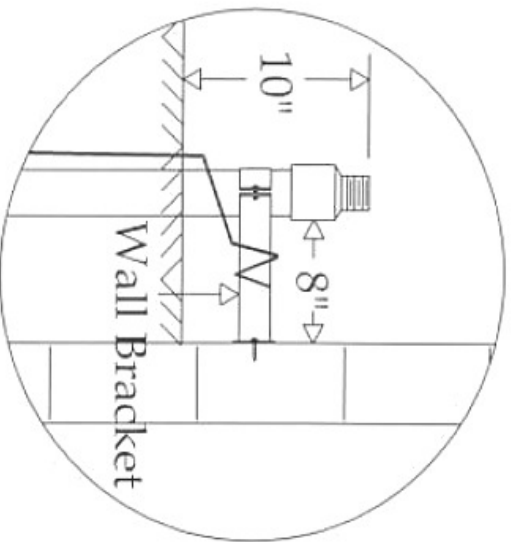
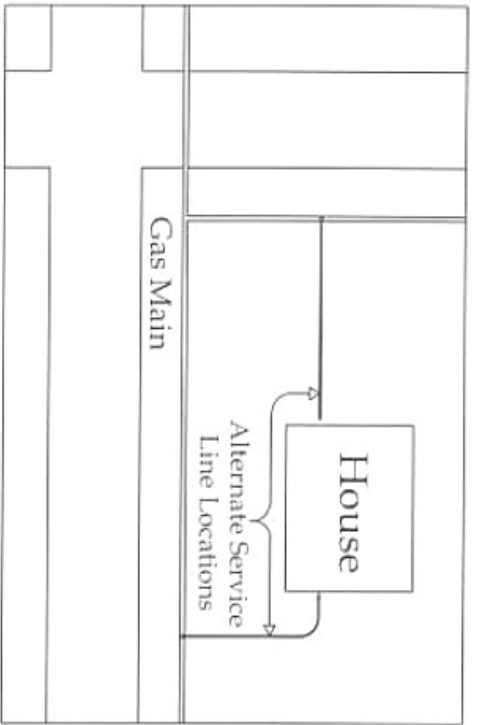

NOTES:

- 1) ONLY PIPE AND FITTINGS APPROVED BY NORTHEAST OHIO NATURAL GAS OR ORWELL NATURAL GAS MAY BE USED.
- 2) ALL MECHANICAL CONNECTIONS ON PLASTIC PIPE MUST BE MADE BY PERSONS QUALIFIED BY NORTHEAST OHIO NATURAL GAS OR ORWELL NATURAL GAS.
- 3) TRACER WIRE IS NOT TO BE IN CONTACT WITH THE SERVICE LINE.

NORTHEAST OHIO NATURAL GAS
ORWELL NATURAL GAS

RESIDENTIAL/SMALL COMMERCIAL
SERVICE LINE DRAWING

PSM - NEO/ORWELL

REVISION - 03-15-2006